

Jan. 3, 1928.

1,655,113

N. TESLA

METHOD OF AERIAL TRANSPORTATION

Filed Sept. 9, 1921

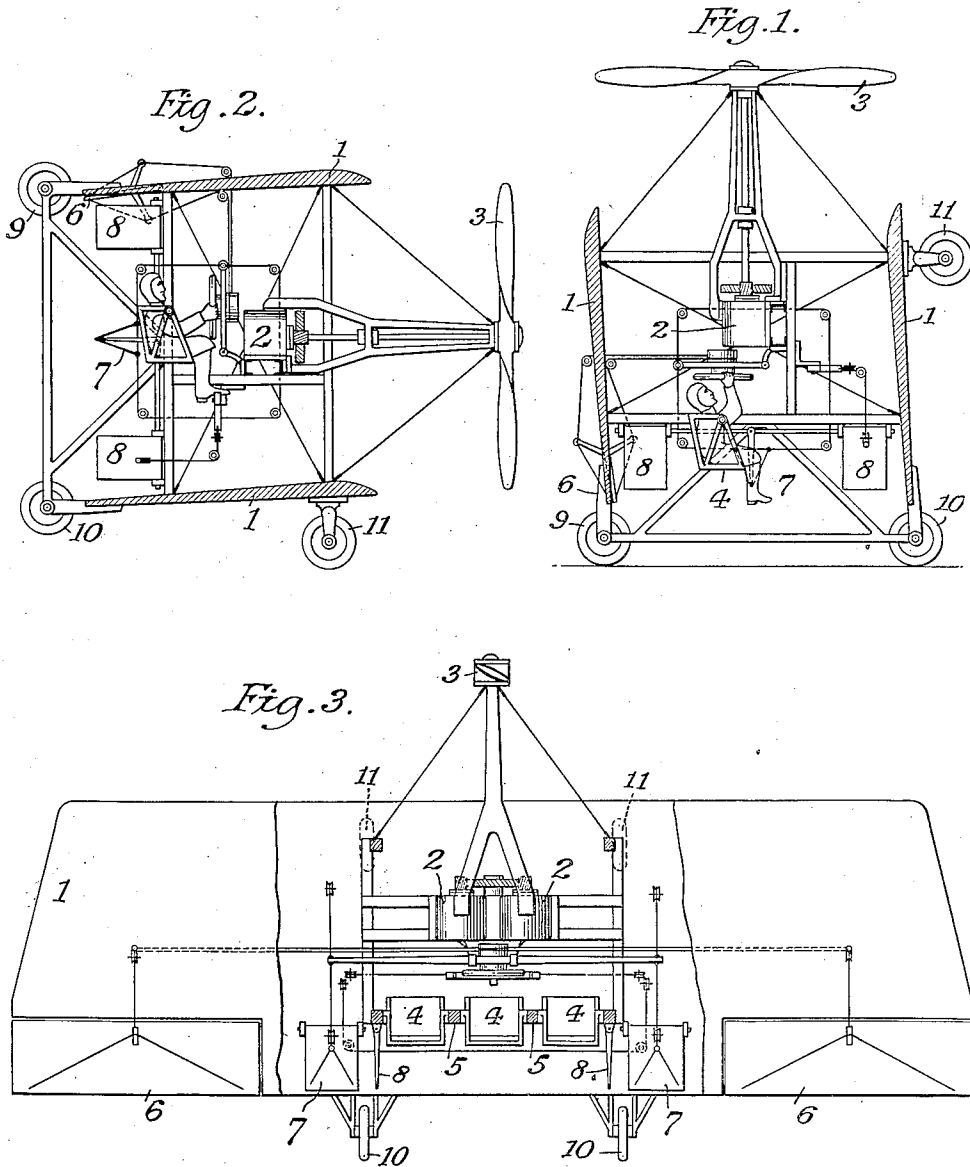

Nikola Tesla INVENTOR
BY *Ken. Sage, Cooper & Haynes* ATTORNEYS

UNITED STATES PATENT OFFICE.

NIKOLA TESLA, OF NEW YORK, N. Y.

METHOD OF AERIAL TRANSPORTATION.

Application filed September 9, 1921, Serial No. 499,519, and in Great Britain April 1, 1921.

The utility of the aeroplane as a means of transport is materially lessened and its commercial introduction greatly hampered owing to the inherent inability of the mechanism to readily rise and alight, which is an unavoidable consequence of the fact that the required lifting force can only be produced by a more or less rapid translatory movement of the planes or foils. In actual experience the minimum speed for ascension and landing is a considerable fraction of that in full flight, and the principles of design do not admit of a very great advance in this respect without sacrifice of some desirable feature. For this reason planes of very large area, high lift wing-sections, deflectors of the slip-stream of the propeller, or analogous means, which might be helpful in these operations, do not afford the remedy sought. This indispensable high velocity, imperilling life and property, makes it necessary to equip the machine with special appliances and provide suitable facilities at the terminals of the route, all of which entail numerous drawbacks and difficulties of a serious nature. So imperative has it become to devise some plan of doing away with these limitations of the aeroplane that the consensus of expert opinion characterizes the problem as one of the most pressing and important and its practical solution is eagerly awaited by those engaged in the development of the art, as well as the general public.

Many attempts have been made to this end, mostly based on the use of independent devices for the express purpose of facilitating and insuring the start and finish of the aerial journey, but the operativeness of the arrangements proposed is not conclusively demonstrated and, besides, they are objectionable, constructively or otherwise, to such an extent that builders of commercial apparatus have so far not considered them of sufficient value to depart from present practice.

More recently, professional attention has been turned to the helicopter which is devoid of planes as distinct organs of support and, presumably, enables both vertical and horizontal propulsion to be satisfactorily accomplished through the instrumentality of the propeller alone. However, although this idea is quite old and not a few experts have endeavored to carry it out in various ways,

no success has as yet been achieved. Evidently, this is due to the inadequacy of the engines employed and, perhaps, also to certain heretofore unsuspected characteristics of the device and fallacies in the accepted theory of its operation, an elucidation of which is deemed necessary for the clear understanding of the subject.

The prospects of a flying machine of this kind appear at first attractive, primarily because it makes possible the carrying of great loads with a relatively small expenditure of energy. This follows directly from the fundamental laws of fluid propulsion, laid down by W. T. M. Rankine more than fifty years ago, in conformity with which the thrust is equal to the integral sum of the products of the masses and velocities of the projected air particles; symbolically expressed,

$$T = \Sigma(mv).$$

On the other hand, the kinetic energy of the air set in motion is

$$E = \Sigma\left(\frac{1}{2}mv^2\right).$$

From these equations it is evident that a great thrust can be obtained with a comparatively small amount of power simply by increasing the aggregate mass of the particles and reducing their velocities. Taking a special case for illustration, if the thrust under given conditions be ten pounds per horse-power, then a hundredfold increase of the mass of air, accompanied by a reduction of its effective velocity to one-tenth, would produce a force of one hundred pounds per horsepower. But the seemingly great gain thus secured is of little significance in aviation, for the reason that a high speed of travel is generally an essential requirement which can not be fulfilled except by propelling the air at high velocity, and that obviously implies a relatively small thrust.

Another quality commonly attributed to the helicopter is great stability, this being, apparently, a logical inference judging from the location of the centers of gravity and pressure. It will be found, though, that contrary to this prevailing opinion the device, while moving in any direction other than up or down, is in an equilibrium easily disturbed and has, moreover, a pronounced

tendency to oscillate. It is true, of course, that when the axis of the propeller is vertical and the ambient air quiescent the machine is stable to a degree, but if it is tilted
 5 even slightly, or if the medium becomes agitated, such is no longer the case.

In explanation of this and other peculiarities, assume the helicopter poised in still air at a certain height, the axial thrust T
 10 just equalling the weight, and let the axis of the propeller be inclined to form an angle α with the horizontal. The change to the new position will have a twofold effect: The vertical thrust will be diminished to

$$15 \quad T_v = T \sin \alpha,$$

and at the same time there will be produced a horizontal thrust

$$20 \quad T_h = T \cos \alpha.$$

Under the action of the unbalanced force of gravity the machine will now fall along a curve to a level below and if the inclination of the propeller as well as its speed of rotation remain unaltered during the descent,
 25 the forces T , T_v , and T_h will continuously increase in proportion to the density of the air until the vertical component T_v of the axial thrust T becomes equal to the gravitational attraction. The extent of the drop will be governed by the inclination of the propeller axis and for a given angle it will be, theoretically, the same no matter at what altitude the events take place. To get an
 30 idea of its magnitude suppose the elevations of the upper and lower strata measured from sea level be h_1 and h_2 , respectively, d_1 and d_2 the corresponding air densities and $H = 26700$ feet the height of the "uniform atmosphere," then as a consequence of Boyle's law
 35 the relation will exist

$$h_1 - h_2 = H \log \frac{d_2}{ed_1}.$$

45 It is evident that

$$\frac{T}{T_v} = \frac{T}{T \sin \alpha} = \frac{1}{\sin \alpha} \text{ must be equal to } \frac{d_2}{d_1}$$

in order that the vertical component of the axial thrust in the lower stratum should
 50 just support the weight. Hence

$$h_1 - h_2 = H \log \frac{1}{\sin \alpha}.$$

55 Taking, in a special case, the angle $\alpha = 60^\circ$, then

$$\frac{1}{\sin \alpha} = \frac{1}{0.866} = 1.1547$$

60 and

$$h_1 - h_2 = 26700 \times \log_e 1.1547 = 3840 \text{ feet.}$$

In reality the drop will be much greater for the machine, upon reaching the lower
 65 layer with a high velocity relative to the

medium, will be urged further down along the curved path and the kinetic energy, in the vertical sense, possessed by the moving mass must be annihilated before the fall is
 70 arrested in a still denser air stratum. At this point the upward thrust will be far in excess of the opposed pull of the weight and the apparatus will rise with first increasing and then diminishing speed to a height which may approximate the original. From there
 75 it will again fall and so on, these operations being repeated during the forward flight, the up and down excursions from the main horizontal line gradually diminishing in magnitude. After a lapse of time, deter-
 80 mined by numerous influences, the excursions should cease altogether and the path described become rectilinear. But this is next to impossible as can be readily shown by pointing out another curious feature of
 85 the helicopter.

In the foregoing the axis of the propeller was supposed to move always parallel to itself, which result might be accomplished
 90 by the use of an adjustable aileron. In this connection it may be pointed out, however, that such a device will not act in the manner of a rudder, coming into full play at intervals only and performing its functions economically, but will steadily absorb energy,
 95 thus occasioning a considerable waste of motive power and adding another to the many disadvantages of the helicopter.

Let now the machine be possessed of a certain degree of freedom, as will be the case
 100 normally, and observe in the first place that the blades of the propeller themselves constitute planes developing a reaction thrust, the pressure on the lower leading blade being
 105 greater than that exerted on the higher one owing to the compression of the air by the body of the machine and increased density in that region. This thrust, tending to diminish the angle α , will obviously vary during one revolution, being maximum in a position when the line of symmetry of the
 110 two propeller blades and that of flight are in a vertical plane and minimum at right angles to it. Nevertheless, when the horizontal speed is great it may be considerable and sufficient to quickly overcome the inertia and gyroscopic resistances all the more readily as the upper blade, which is situated in a region where the conditions are more nearly
 115 normal, operates to the same effect. Moreover, this disturbing effect partakes of the regenerative quality, the force increasing as the angle diminishes up to a maximum for $\alpha = 45^\circ$. As the axis is tilted more and more, the vertical sustaining effort of the propeller will correspondingly diminish and the machine will fall with a rapidly increasing
 120 velocity; finally exceeding the horizontal when the reaction of the blades will be directed upward so as to increase the angle
 125
 130

α and thereby cause the machine to soar higher. Thus periodic oscillations, accompanied by ascents and descents, will be set up which may well be magnified to an extent such as to bring about a complete overturn and plunge to earth.

It is held by some experts that the helicopter, because of its smaller body resistance, would be capable of a higher speed than the aeroplane. But this is an erroneous conclusion, contrary to the laws of propulsion. It must be borne in mind that in the former type, the motive power being the same, a greater mass of air must be set in motion with a velocity smaller than in the latter, consequently it must be inferior in speed. But even if the air were propelled in the direction of the axis of the screw with the same speed V in both of them, while the aeroplane can approximate the same, the helicopter could never exceed the horizontal component $V \cos \alpha$. To be explicit, imagine that the air current flowing with the velocity V along the propeller axis inclined to form an angle α with the horizontal, be replaced by two streams one vertical and the other horizontal of velocities respectively equal to $V \sin \alpha$ and $V \cos \alpha$, it will be evident that a helicopter in its forward flight could only approximate and never equal the speed $V \cos \alpha$ of the horizontal air current no matter how much the resistance be reduced for, according to a fundamental law of propulsion, the thrust would be nil at that velocity. The highest efficiency should be obtained with the machine proceeding at the rate $\frac{1}{2} V \cos \alpha$ but the most economical utilization of power would be effected when $\alpha = 45^\circ$ in which case the speeds of both the horizontal and vertical streams will be $0.7 V$. From this it may be inferred that, theoretically, the best performance might be secured in propelling the helicopter forward with a speed more or less approximating $0.35 V$ but the results attained in practice will be necessarily much inferior because without special provisions such as are herein set forth the device, as pointed out above, would plunge down and shoot up in succession, at the same time executing smaller oscillations, which motions will retard its flight and consume a considerable portion of the motive energy all the more so as the losses incident to the controlling means will be correspondingly increased.

Another very serious defect of this kind of flying machine, from the practical point of view, is found in its inability of supporting itself in the air in case of failure of the motor, the projected area of the propeller blades being inadequate for reducing the speed of the fall sufficiently to avoid disaster, and this is an almost fatal impediment to its commercial use.

From the preceding facts, which are ignored in the technical publications on the subject, it will be clear that the successful solution of the problem is in a different direction.

My invention meets the present necessity in a simple manner without radical departure in construction and sacrifice of valuable features, incidentally securing advantages which should prove very beneficial in the further development of the art. Broadly expressed, it consists in a novel method of transporting bodies through the air according to which the machine is raised and lowered solely by the propeller and sustained in lateral flight by planes. To accomplish this a light and powerful prime-mover is necessary and as particularly suited for the purpose I employ, preferably, a turbine of the kind described in my U. S. Patent No. 1,061,206, of May 6, 1913, which not only fulfills these requirements, but is especially adapted to operation at high temperature. I also make arrangements whereby the flying machine may be, automatically or at will of the operator, caused to function either as a helicopter or an aeroplane.

Full knowledge of these improvements will be readily gained by reference to the accompanying drawings in which Fig. 1 illustrates the machine in the starting or landing position and Fig. 2, in horizontal flight. Fig. 3 is a plan view of the same with the upper plane partly broken away.

The structure is composed of two planes or foils 1, 1 rigidly joined. Their length and distance apart may be such as to form a near-square for the sake of smallness and compactness. With the same object the tail is omitted or, if used, it is retractable. The motors 2, 2 in this case turbines of the kind described in my patent before referred to, and other parts of the motive apparatus are placed with due regard to the centers of gravity and pressure and the usual controlling means are provided. In addition to these any of the known stabilizing devices may be embodied in the machine. At rest the planes are vertical, or nearly so, and likewise the shaft driving the propeller 3, which is constructed of a strength, size and pitch that will enable it to raise the entire weight with the motors running at an even greater rate than when propelling the machine horizontally. Power is transmitted to the shaft from the turbines through suitable gears. The seats 4, 4, 4 for the operator and passengers are suspended on trunnions 5, 5 on which they can turn through an angle of about 90° , springs and cushions (not shown) being employed to insure and limit their motion through this angle. The usual devices for lateral and directional control, 6, 6 7, 7 and 8, 8 are pro-

vided with mechanical connections enabling the operator to actuate the devices by hand or foot from his seat in any position. At the start, sufficient power being turned on by suitable means, also within his reach, the machine rises vertically in the air to the desired height when it is gradually tilted by manipulating the elevator devices and proceeds like an aeroplane, the load being transferred from the propeller to the foils as the angle of inclination diminishes and the speed in horizontal direction increases. From the foregoing it will be understood that, simultaneously with the tilting of the machine, the operator will increase the thrust of the propeller in order to compensate for the reduction of sustaining force which follows inevitably from the diminution of angle α and before the reaction of the planes can come into full effect. He will thus prevent a downward plunge and the production of dangerous oscillations which have been dwelt upon above, and by suitable manipulation of the apparatus and gradual cutting down of the power developed by the prime mover, as forward velocity is gained and the planes take up the load, he may cause the machine to advance horizontally along a sensibly straight line, a condition essential to the attainment of the best practical results. In descending, the forward speed is reduced and the machine righted again, acting as a helicopter with the propeller supporting all the load. Obviously, as the device is slowed down and righted causing the planes to lose part or all of their sustaining efforts, the operator will apply more power to the propeller increasing thereby the thrust to the required magnitude and in all such operations of starting and loading as well as tilting for regulating the height, meeting the air conditions or for other purposes it will be his object to modify the propeller thrust in about the same measure as the varying reaction of the planes may demand in order that the lifting force be sensibly constant. Evidently also, whenever necessary or desirable, power far in excess of that normally required may be applied during the flight and the machine propelled at a greatly increased speed. The type of turbine used is a motor of great lightness and activity and lends itself exceptionally to this kind of work for which ordinary aviation motors are unsuited. It is capable of carrying a great overload and running without danger at excessive speed so that during the starting and landing operations the necessary power can be developed by the motors even though less efficiently than under their normal working conditions. Special means of control may be provided, if necessary, for increasing the power supply in these operations. Owing to its extreme simplicity the motive apparatus is very reli-

able in operation, but should the power give out accidentally, landing can still be easily effected by volplaning. For this purpose, in addition to wheels 9, 9 and 10, 10 wheels 11, 11 are employed, the latter being mounted on the forward end under the lower plane and, so that when the machine rests on level ground the propeller shaft will have the desired inclination which is deemed best for rising in the manner of an aeroplane. Such an aeroplane constructed and operated as described, unites the advantages of both types and seems to meet best the requirements of a small, compact, exceedingly speedy and yet very safe machine for commercial use. Especially good practical results are obtainable by the use of my turbine which can be depended upon to develop the necessary energy for lifting, even if it should be considerably greater than that consumed in flight under normal conditions. This end can be conveniently attained by temporarily supplying more of the working fluid to the rotor and driving it faster, or running it at about the same speed and increasing the effort by adjustment of the pitch of the propeller, or other means known in the art. The latter should be designed to work most economically during the flight, as its efficiency in the starting and landing operations is of relatively small importance. Instead of a single large screw as described a number of smaller ones may be used, in which case gearing can be dispensed with. The biplane seems to be best suited for the chief purpose contemplated but the invention is applicable to monoplanes and other types.

To sum up, the helicopter type of flying machine, especially with large inclination angle of the propeller axis to the horizontal, at which it is generally expected to operate, is quite unsuitable for speedy aerial transport; it is incapable of proceeding horizontally along a straight line under the prevailing air conditions; it is subject to dangerous plunges and oscillations and, what is most important from the commercial and practical point of view, it is almost certainly doomed to destruction in case the motive power gives out. These drawbacks and defects are overcome by the methods and apparatus I have described through which a novel type of flying machine may be realized possessing all the advantages of the helicopter being at the same time safe and capable of a speed equal to or even greatly exceeding that of the present aeroplane.

To my knowledge various forms of aeroplanes have been proposed with the object of attaining similar results but a careful study shows that none of them is capable of the actions as those here contemplated for want of proper methods of operation as well as suitable apparatus.

I do not claim herein the ap by

means of which this method is or may be carried out either in the special form illustrated or in modifications of the same, as this is the subject of a separate application.

5 What I desire to secure by Letters Patent is:

1. The hereinbefore described method of aeroplane transportation which consists in developing by the propelling device, a vertical thrust in excess of the normal, causing thereby the machine to rise in an approximately vertical direction, tilting it and simultaneously increasing the power of the motor and thereby the propeller thrust, then gradually reducing the power and thrust as forward speed is gained and the planes take up the load, thus maintaining the lifting force sensibly constant during flight, tilting the machine back to its original position and at the same time increasing the power of the motor and thrust of the propeller and effecting a landing under the restraining action of the same.

2. The method of operating a helicopter which consists in varying the power of the motor and thereby the thrust of the propeller

according to the changes of inclination of its axis, so as to maintain the lifting force sensibly constant during the forward flight.

3. The above described method of transporting from place to place a heavier than air flying machine, which consists in applying power to the propeller while its axis is in a vertical position sufficient to cause the machine to rise, tilting it and at the same time applying more power to increase the thrust, then gradually diminishing the power as the load is transferred from the propeller to the planes, tilting back the machine and so controlling the applied power as to effect a slow descent upon the landing place under the restraining action of the propeller.

4. In the transport of bodies by aeroplane, the method of controlling the propeller thrust and reaction of the planes by varying the power of the motor correspondingly with the inclination of the machine so as to maintain the lifting force sensibly constant during the forward flight.

In testimony whereof I hereto affix my signature.

NIKOLA TESLA.