

N. TESLA.
ELECTRICAL CIRCUIT CONTROLLER.

(Application filed Dec. 2, 1897.)

(No Model.)

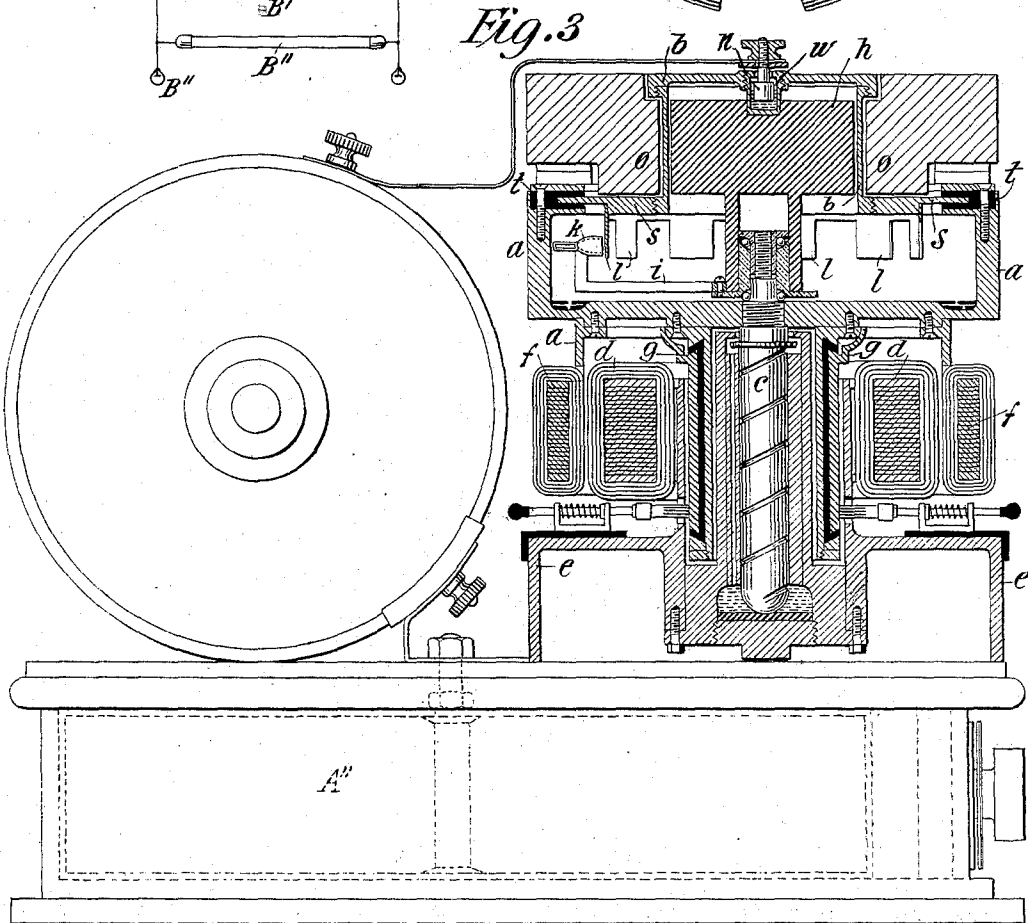
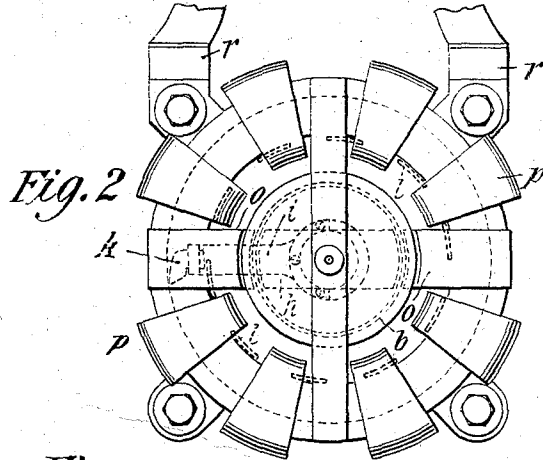
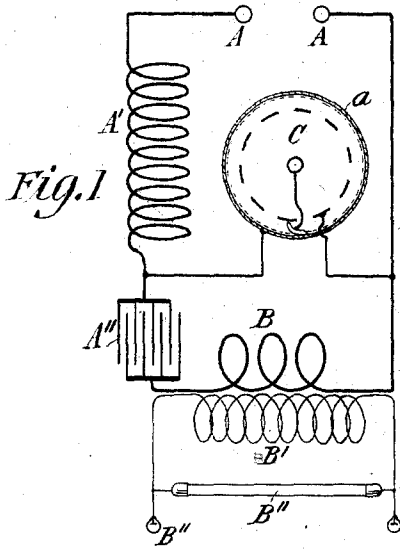

Witnesses:
Raphaël Vetter
M. Lamson Jnr.

Nikola Tesla, Inventor
 by *Kerr, Curtis & Page* Attys

UNITED STATES PATENT OFFICE.

NIKOLA TESLA, OF NEW YORK, N. Y.

ELECTRICAL-CIRCUIT CONTROLLER.

SPECIFICATION forming part of Letters Patent No. 609,245, dated August 16, 1898.

Application filed December 2, 1897. Serial No. 660,518. (No model.)

To all whom it may concern:

Be it known that I, NIKOLA TESLA, residing at New York, in the county and State of New York, have invented certain new and useful Improvements in Electrical-Circuit Controllers, of which the following is a specification, reference being had to the drawings accompanying and forming a part of the same.

In every form of electrical apparatus involving a means for making and breaking, more or less abruptly, a circuit a waste of energy occurs during the periods of make or break, or both, due to the passage of the current through an arc formed between the receding or approaching terminals or contacts, or, more generally, through a path of high resistance. The tendency of the current to persist after the actual disjunction or to precede the conjunction of the terminals exists in varying degrees in different forms of apparatus, according to the special conditions present. For example, in the case of an ordinary induction-coil the tendency to the formation of an arc at the break is, as a rule, the greater, while in certain forms of apparatus I have invented in which the discharge of a condenser is utilized this tendency is greatest at the instant immediately preceding the conjunction of the contacts of the circuit-controller which effects the discharge of the condenser.

The loss of energy occasioned by the causes mentioned may be very considerable and is generally such as to greatly restrict the use of the circuit-controller and render impossible a practical and economical conversion of considerable amounts of electrical energy by its means, particularly in cases in which a high frequency of the makes and breaks is required.

Extended experiment and investigation conducted with the aim of discovering a means for avoiding the loss incident to the use of ordinary forms of circuit-controllers have led me to recognize certain laws governing the waste of energy and making it dependent chiefly on the velocity with which the terminals approach and recede from one another and also more or less on the form of the current-wave. Briefly stated, from both theoretical considerations and practical experiment it appears that the loss of energy

in any device for making and breaking a circuit, other conditions being the same, is inversely proportional rather to the square than to the first power of the speed or relative velocity of the terminals in approaching and receding from one another in an instance in which the current-curve is not so steep as to materially depart from one which may be represented by a sine function of the time; but such a case seldom obtains in practice. On the contrary, the current-curve resulting from a make and break is generally very steep and particularly so when, as in my system, the circuit-controller effects the charging and discharging of a condenser, and consequently the loss of energy is still more rapidly reduced by increased velocity of approach and separation. The demonstration of these facts and the recognition of the impossibility of attaining the desired results by using ordinary forms of circuit-controllers led me to invent new and essentially different means for making and breaking a circuit in which I have utilized a conducting fluid, such as mercury, as the material for one or both of the terminals and devised novel means for effecting a rapidly-intermittent contact between the fluid and a conductor or series of conductors forming the other terminal.

With a view, however, to securing a more practical and efficient circuit-controller in which not only the relative speed of the terminals but also the frequency of the makes and breaks should be very high I devised the form of instrument described in an application filed by me June 3, 1897, Serial No. 639,227, in which a receptacle is rotated to impart a rapid movement to a body of conducting fluid contained therein, which is brought in rapidly-intermittent contact with a conductor having peripheral projections extending into the fluid, the movement of the latter being conveniently utilized to rotate the conductor. Such a device, though meeting fully many requirements in practice, is nevertheless subject to certain limitations in the matter of attaining a high relative speed of approach and separation of the terminals, since the path of movement of the conducting projections is not directly away from and toward the fluid, but more or less tangential to the surface of the latter, the velocity of

approach and separation being of course the smaller the greater the diameter of the rotated conductor or terminal.

5 With the object of securing a greater relative speed of the terminals and a consequently more efficient form of circuit-controller of this type I devised the modified form of apparatus which constitutes the subject of my present application.

10 In this apparatus one of the members or terminals is a conducting fluid which is caused to issue from an orifice against a series of spaced conductors in rapid succession. For this purpose the series of conductors, or it
15 may be a single conductor, is moved transversely through the stream or jet of fluid, or the jet is moved so as to impinge upon the conductors, or both jet and conductors are moved. This is preferably accomplished by
20 mounting the conductors and the tube or duct from which the fluid issues concentrically and revolving one or both.

The chief feature of novelty which distinguishes the apparatus and in which my improvement resides is the plan adopted for
25 maintaining the stream or jet of conducting fluid. This consists in utilizing the same power that actuates or drives the circuit-controller in effecting the necessary relative
30 movement of its terminals to maintain the proper circulation of the conducting fluid by combining the two mechanisms (the controller and the means for maintaining a circulation of the conducting fluid) in one. This
35 feature is of great practical advantage and may be effected in many ways. A typical arrangement for this purpose is to provide a tube or duct having an orifice at one end directed toward the spaced conductors and its
40 other end in a position to take up a portion of the rapidly-rotating body of conducting fluid, divert it through the duct, and discharge it against the conductors. With this object when a closed receptacle is used a holder for
45 the tube is employed, mounted within the receptacle and concentrically therewith, and this holder, when the receptacle is revolved, is held or influenced by any suitable means, as by magnetic attraction exerted from the
50 outside or otherwise, in such manner as to keep it either in a fixed position or impress upon it a velocity different from that of the rotated fluid.

55 Such other improvements in details as I have devised and applied to the construction and operation of my improved circuit-controller will be more fully hereinafter described; but from the above general statement of the nature of the device it will be observed
60 that by means of the same the velocity of relative movement of the two parts or elements may be enormously increased and the duration of the arc or discharge between them at the periods of make and break thereby
65 greatly reduced without material increase in the power required to effect it and without

impairing the quality of contact or deteriorating the terminals.

In the drawings hereto annexed, Figure 1 is a diagram illustrating the system for which
70 the improvement was more especially designed. Fig. 2 is a top plan view of the circuit-controller. Fig. 3 is a view showing the induction-coil of Fig. 1 with its condenser-case in side elevation and the circuit-con-
75 troller in vertical central section.

The general scheme of the system for use with which my improved circuit-controller is more especially designed will be understood
80 by a brief reference to Fig. 1. In said figure, A A represent the terminals of a source of current. A' is a self-induction or choking coil included in one branch of the circuit and permanently connected to one side of a
85 condenser A''. The opposite terminal of this condenser is connected to the other terminal of the source through the primary B of a transformer, the secondary B' of which supplies the working circuit containing any suitable
90 translating devices, as B''.

The circuit-controller C, which is represented conventionally, operates to make and
break a bridge from one terminal of the source to a point between the choking-coil
95 A' and the condenser A'', from which it will result that when the circuit is completed through the controller the choking-coil A' is short-circuited and stores energy which is discharged into the condenser when the
100 controller-circuit is broken, to be in turn discharged from the condenser through the primary B when these two are short-circuited by the subsequent completion of the controller-circuit.

I refer now to Figs. 2 and 3 for an illustration of the more important and typical
105 features of my improved circuit-controller. The parts marked *a* compose a closed receptacle of cylindrical form having a dome or extension of smaller diameter. The receptacle
110 is secured to the end of a spindle *c*, which is mounted vertically in bearings of any character suitable for the purpose. As it is intended to impart a rapid rotation to the receptacle *a*, I have shown a convenient
115 device for this purpose comprising a field-magnet *d*, secured to the base or frame *e*, and an annular armature *f*, secured to the receptacle *a*. The coils of the armature are connected with the plates *g* of a commutator
120 secured to the receptacle *a* and made in cylindrical form, so as to surround the socket in which the spindle *c* is stepped. A body of magnetic material *h*, which serves as an armature, is mounted on antifriction-bearings
125 on an extension of the spindle *c*, so that the receptacle and the body *h* may have freely independent movements of rotation. Surrounding the dome *b*, in which the armature *h* is contained, is a core with pole-pieces
130 *o*, which are magnetized by coils *p*, wound on the core. The said core is stationary, being

supported by arms *r*, Fig. 2, independently of the receptacle, so that when the receptacle is rotated and the core energized the attractive force exerted by the poles *o* upon the armature *h* within the receptacle *a* holds the said armature against rotation. To prevent loss from currents set up in the shell of the dome *b*, the latter should be made of German silver or other similar precaution taken. An arm *i* is secured to the armature *h* within the receptacle *a* and carries at its end a short tube *k*, bent, as shown in Fig. 2, so that one open end is tangential to the receptacle-wall and the other directed toward the center of the same. Secured to the top plate of the receptacle *a* are a series of conducting-plates *l*. The part of the top plate *s* from which said conducting-plates *l* depend is insulated from the receptacle proper by insulating packing-rings *t*, but is electrically connected with the dome *b*, and in order to maintain electrical connection from an external circuit to the conductors *l* a mercury-cup *w* is set in the top of the dome, into which cup extends a stationary terminal plug *n*. A small quantity of a conducting fluid, such as mercury, is put into the receptacle *a*, and when the latter is rotated the mercury by centrifugal action is forced out toward its periphery and rises up along its inner wall. When it reaches the level of the open-mouthed tube *k*, a portion is taken up by the latter, which is stationary, and forced by its momentum through the tube and discharged against the conductors *l* as the latter pass in rapid succession by the orifice of said tube. In this way the circuit between the receptacle and the conductors *l* is completed during the periods in which the stream or jet of mercury impinges upon any of the conductors *l* and broken whenever the stream is discharged through the spaces between the conductors.

From the nature of the construction and mode of operation of the above-described apparatus it is evident that the relative speed of separation and approach of the two elements or terminals (the jet and the conductors *l*) may be extremely high, while such increased speed affects in no material respect the quality of contact.

A circuit-controller of the kind described is applicable and useful in many other systems and apparatus than that particularly described herein, and may be greatly modified in construction without departure from the invention.

I am aware that a jet or stream of conducting fluid has heretofore been employed as a means for completing an electric circuit, and I do not claim, broadly, the employment of a conducting fluid in such form as a contact or terminal; but so far as I am aware both the purpose for which I employ such form of contact or terminal and the manner in which I apply it are wholly of my invention, neither having been heretofore proposed.

What I claim is—

1. The combination with a receptacle of a conductor or series of spaced conductors, a nozzle or tube for directing a jet or stream of fluid against the same, the nozzle and conductor being capable of movement relatively to each other, and means for maintaining a circulation of conducting fluid, contained in the receptacle, through the said nozzle, and dependent for operation upon such relative movement, as set forth.

2. The combination with a closed receptacle of a conductor or series of spaced conductors, a nozzle or tube for directing a jet or stream of fluid against the same, and means for forcing a conducting fluid contained in the receptacle through the said nozzle, these parts being associated within the receptacle and adapted to be operated by the application of a single actuating power, as set forth.

3. The combination with a receptacle containing a series of spaced conductors, a duct within the receptacle having one of its ends directed toward the said conductors, means for maintaining a rapid movement of relative rotation between the said end and the conductors and means for maintaining a circulation of a conducting fluid contained in the receptacle through the duct against the conductors, the said conductors and jet constituting respectively the terminals or elements of an electric-circuit controller.

4. The combination with a receptacle capable of rotation and containing a series of spaced conductors, a duct within the receptacle having an orifice directed toward the said conductors, and an open end in position to take up a conducting fluid from a body of the same contained in the receptacle, when the latter is rotated, and direct it against the conductors, the said conductors and the fluid constituting the terminals or elements of an electric-circuit controller.

5. The combination with a receptacle for containing a conducting fluid and a series of spaced conductors thereon, of a duct having an orifice directed toward the said conductors and forming a conduit through which the fluid when the receptacle is rotated is forced and thrown upon the conductors.

6. The combination with a receptacle capable of rotation, and a series of conductors mounted therein, of a duct having an orifice directed toward the conductors, a holder for said duct mounted on bearings within the receptacle which permit of a free relative rotation of said receptacle and holder, and means for opposing the rotation of the said holder in the direction of the movement of the fluid while the receptacle is rotated, whereby the conducting fluid within the receptacle will be caused to flow through the duct against the conductors.

7. The combination with a receptacle and a motor for rotating the same, of a magnetic body mounted in the receptacle, a magnet exterior to the receptacle for maintaining the body stationary while the receptacle rotates,

a series of conductors in the receptacle and a duct carried by the said magnetic body and adapted to take up at one end a conducting fluid in the receptacle when the latter rotates
5 and to direct such fluid from its opposite end against the series of conductors.

8. The combination with a receptacle for containing a conducting fluid, a series of spaced conductors within the same, and a
10 motor, the armature of which is connected with the receptacle so as to impart rotation thereto, a magnetic body capable of turning

freely within the receptacle about an axis concentric with that of the latter, a duct carried by the said body having one end in po- 15
sition to take up the conducting fluid and the other in position to discharge it against the spaced conductors, and a magnet exterior to the receptacle for holding the magnetic body stationary when the receptacle is rotated. 20

NIKOLA TESLA.

Witnesses:

M. LAWSON DYER,
G. W. MARTLING.