

Oct. 13, 1931.

C. J. BRITTEN

1,826,727

RADIO APPARATUS

Filed April 30, 1928

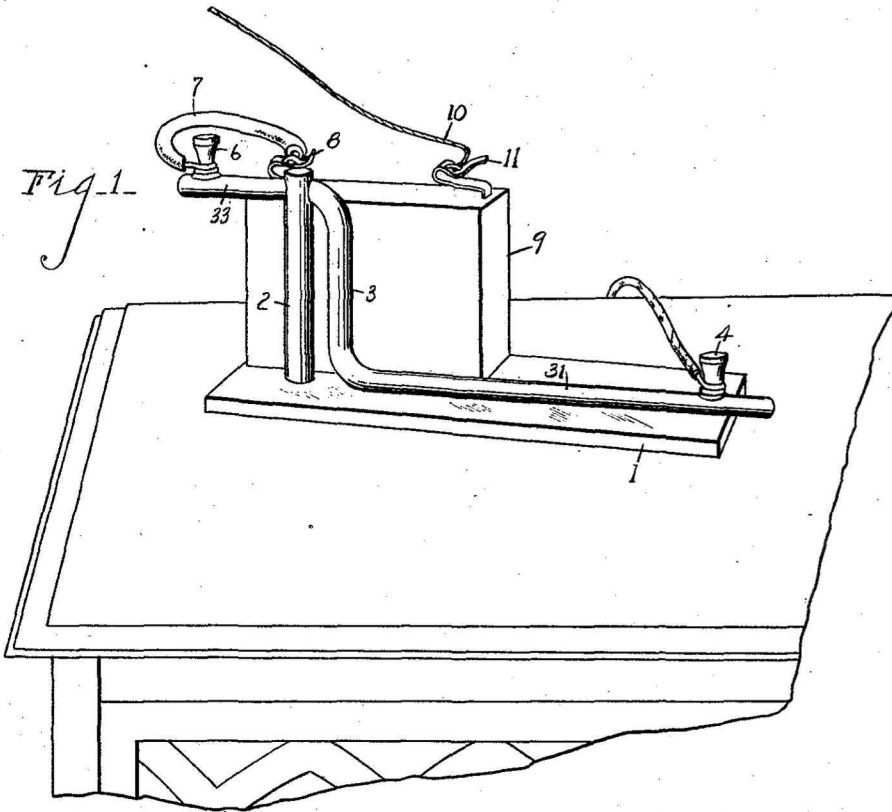

Fig. 1.

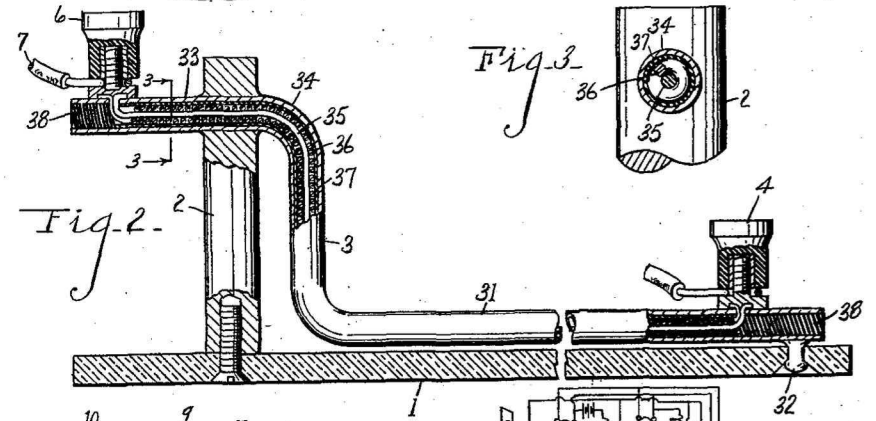

Fig. 2.

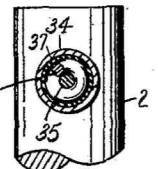

Fig. 3.

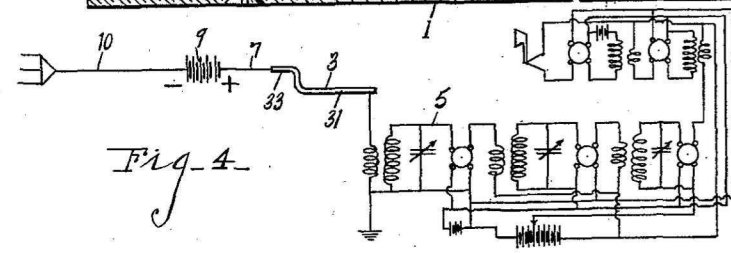

Fig. 4.

INVENTOR
Chancy J. Britten
By Chappell & Earl
ATTORNEYS

