

[54] **METHOD AND MEANS FOR GENERATING EXPLOSIVE FORCES**

[72] *Inventor: Josef Papp, San Pedro, Calif.*
 [73] *Assignee: Envirometics, Inc., Gardena, Calif.*
 [22] *Filed: Nov. 1, 1968*
 [21] *Appl. No.: 772,653*

[52] *U.S. Cl. 89/7, 176/1*
 [51] *Int. Cl. F41F*
 [58] *Field of Search 89/7, 8*

[56] **References Cited**

UNITED STATES PATENTS

2,783,684	3/1957	Yoler.....	89/7
2,899,864	8/1959	Bloxom, Jr.	89/7
3,086,424	4/1963	Liao.....	89/8

Primary Examiner—Reuben Epstein
Attorney—Miketta, Glenn, Poms and Smith

[57] **ABSTRACT**

A method of generating explosive forces involving the triggering and utilization of potential energy of atoms and various forms of radiation and emanation; the provision of environmental means in which the reaction can be initiated by electrical means. The utilization of elements of relatively low atomic number, such as the noble gases, chlorine and other elements and their isotopes whose atoms do not have their outer quantum levels completely satisfied with orbital electrons, in the production of explosive reactions in which fission, spallation, transfer reactions and cascade effects appear to be utilized. The utilization of elements having the property of emitting electrons, alpha gamma and beta radiations, X-ray and ultraviolet emanations for the purpose of triggering the reactions.

13 Claims, 3 Drawing Figures

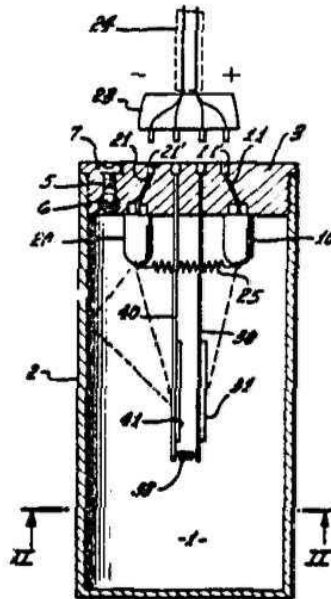

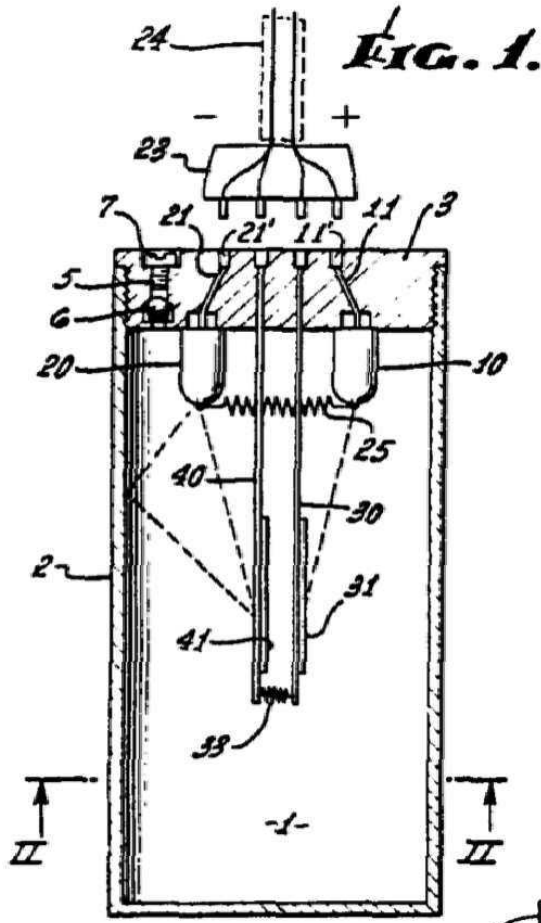

FIG. 1.

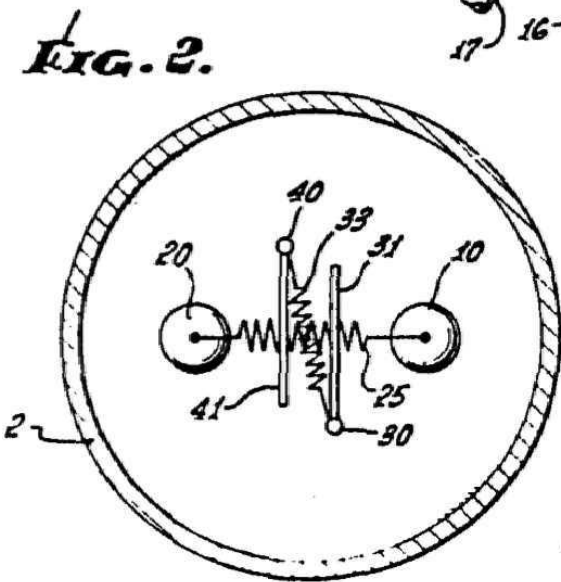

FIG. 2.

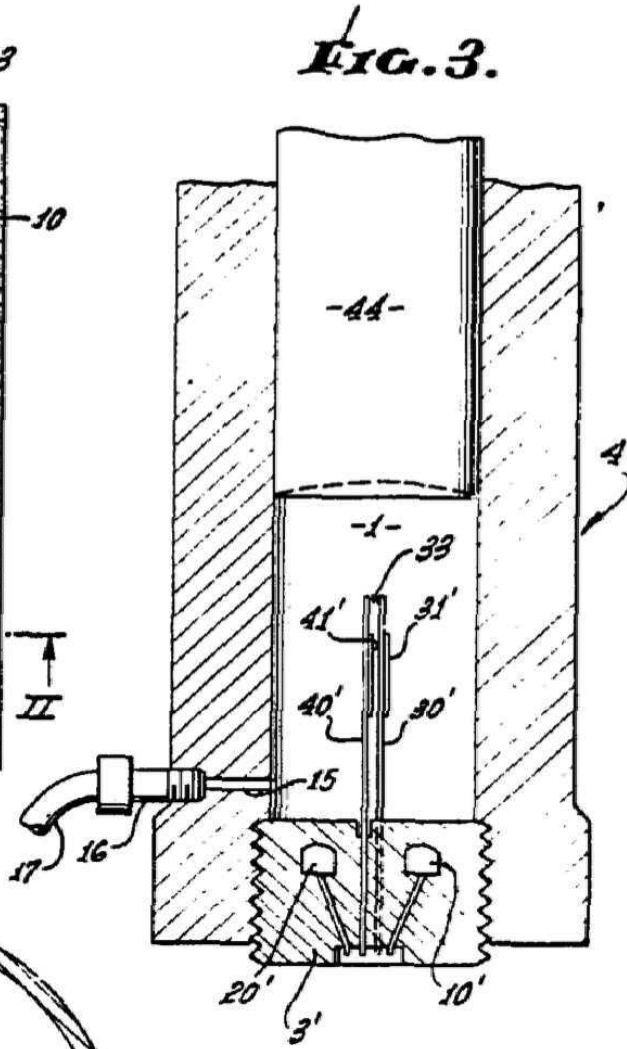

FIG. 3.

INVENTOR
JOSEF PAPP
BY
Miketta, Janny, Papp & Smith
ATTORNEYS.

METHOD AND MEANS FOR GENERATING EXPLOSIVE FORCES

This invention is directed to a method of generating explosive forces by the utilization of relatively inexpensive chemical elements and their isotopes, the reactions being triggered by radiations and emanations from other elements (which radiations and emanations may be stimulated by the application of electrical energy), the reactions taking place almost instantaneously with the liberation of a tremendous amount of energy. Various mechanisms involving fragmentation of atoms and nuclides, spallation, fission, cascade effects, etc. are believed to take place. One of the advantages of the present invention is that the elements employed are readily available, do not require the utilization of uranium or plutonium and do not result in radioactive products having the potential dangers of previously known explosive charges utilizing atomic energy.

Briefly stated, the present invention employs a trapped volume of a mixture of gases, preferably noble gases such as argon, krypton, neon, xenon and their isotopes, since these gases do not burn, do not contain or produce acid containing materials which deleteriously affect containers and are sensitive to and respond to radiations. These and other gases and elements from periods 2, 3, 4 and 5 of the periodic table whose atoms do not have their outer quantum levels completely satisfied with orbital electrons, and whose electron distances permit electron connections, are capable of being utilized. Isotopes of the above are often capable of internal electron conversion readily and are also effective. Chlorine is an example.

The invention also contemplates the utilization of elements adapted for use in activating the reaction. Elements used in the cells are preferably those capable of emitting electrons, alpha rays, beta rays, gamma rays and X-rays; negative beta rays are particularly useful. Example of elements adapted for use in these cells include rubidium, red and white phosphorous, mesothorium, radium and other elements which decay by the emission of negative beta particles and which are also subject to rearrangement within the atom or decay by orbital electron capture. Similarly, atoms which exhibit alpha particle emission can be employed.

An advantage of the present invention lies in that most of the elements employed are readily available and inexpensive; they are not dangerously radioactive. The explosive charge of gases need not be under a pressure exceeding 3 or 4 atmospheres. The charge is stable, will not burn and is unaffected by changes in temperature. The explosive is detonated by supplying the activating cells and electrodes within the charge with current at a voltage and amperage which is readily obtainable from a small generator.

Among the objects of this invention I list:

1. The utilization of noble gases and similar elements as herein disclosed in the production of explosives.
2. The utilization of noble gases and elements capable of activating said gases as herein disclosed.
3. A method of generating explosive forces within a chamber containing a volume of a mixture of gases by subjecting the gases to radiations and emanations of electrons, beta rays, gamma rays, alpha rays and X-rays and an electrical discharge.

4. To disclose and provide certain exemplary forms of arrangements employing the method whereby the

method may be effectively utilized in the generation of explosive forces both for industrial purposes (as in mining, the formation of underground caverns for the recovery of shale oil, hydrocarbon gases, etc.) and in military purposes, the method being particularly adapted for use in space as well as under the seas and on land.

5. To disclose and provide exemplary compositions, proportions and conditions under which the method may be carried out.

Other advantages will readily occur to those skilled in this art from the following description. For purposes of illustration and to facilitate understanding, and without limitation thereto, certain exemplary forms of arrangements in which the method may be carried out will be described by reference to the following drawings in which:

FIG. 1 is a somewhat diagrammatic longitudinal section through a canister or charge chamber in which the explosion may take place;

FIG. 2 is a transverse section taken along the plane II-II in FIG. 1;

FIG. 3 is a diagrammatic longitudinal section taken through a breach portion of a gun barrel in which the method of the present invention may be employed in generating an explosive force adapted to eject a missile from such barrel.

The form of device illustrated in FIGS. 1 and 2 has many uses, but is particularly well adapted for use in mining, in cracking underground formations to facilitate the recovery of oil or make underground oil shale beds release oil, etc. The device there shown includes an external, cylindrical housing 2 provided with a base 3 and having an enclosed end so as to provide a substantially gas-tight chamber 1. Affixed to the base 3, interiorly of the housing are a pair of activating cells 10 and 20 spaced from each other; each of these cells is hollow and contains a quantity of an element capable of emitting the desired radiations of the character hereinbefore referred to. These hollow cells may be made of stainless steel, duraluminum, or aluminum alloys containing zinc, antimony and cesium. The quantity of rubidium, phosphorous, mesothorium, radium or other elements capable of emitting electrons, alpha rays, beta rays, gamma rays, X-rays etc. may vary with the size of chamber 1 and the effect desired during explosion. Preferably, the cells contain the elements in an atmosphere of argon. The base of each cell is electrically connected as at 11 and 21 to a female electrical connector such as 11' and 21' carried by the base and adapted to receive the male current supplying jack of a suitable plug 23.

Extending into the chamber 1 from the base 3 is a pair of spaced electrodes 30 and 40, each of these electrodes carrying a capacitor plate 31 and 41 respectively approximately in the central portion of the chamber. The capacitor plates may be made of any suitable metal, such as aluminum, and may be suitably spaced by means of one or more small, dielectric spacers so as to permit the mixture of gases within the chamber to readily pass between the capacitor plates. The inner ends of the two electrodes 30 and 40 are connected as indicated at 33 by means of a coil of wire capable of becoming incandescent when supplied with current. Wolfram is eminently suited for this purpose. The ends

of the electrodes within the base 3 are also connected to suitable female terminals adapted to cooperate with contact points of a plug indicated at 23 of a cable 24.

The device illustrated also indicates the inner ends of the cells 10 and 20 as being connected by another coil 25 of thin wire which normally would not glow or become incandescent under the loads to which coil 33 is subjected, but which will become incandescent in the event a larger current is supplied to the device.

The base 3 is also shown provided with an injection port 5 and a removable exterior plug or closure 7, which, when removed, permits the injection of a charge of mixed gases into the chamber past a check valve 6. In practice, it is desirable to purge the interior of chamber 1 or to partly evacuate it before injection of the mixture of gases being employed.

Typical gas compositions which have been employed in these charges comprise:

Argon	between about 40% and 60%
Neon	between about 6% and 8%
Xenon	between about 30% and 40%
Chlorine	less than 1%
Deoxygenated Water	less than 1%

When the chamber 1 had a volumetric capacity of about 15.5 cubic inches, one of the cells may be charged with 3 grams of rubidium and the other cell can be charged with 4 to 5 grams of phosphorous. Extremely efficient explosive charges may be obtained by the use of smaller quantities of mesothorium in one cell and radium in another. In a specific test in which a 15- $\frac{1}{2}$ inch cubic charging chamber was employed, the two capacitor plates were each one eighth inch thick by 1- $\frac{1}{4}$ inch wide by 2- $\frac{1}{2}$ inches long and were spaced one fourth inch apart. The heating coil 33 in that instance was made from a 2- $\frac{1}{2}$ inch length of wolfram about 0.03 inches in diameter. The cable 24 was connected to a small generator supplying 35 volt AC at 1- $\frac{1}{2}$ amperes. One of the cells and one of the electrodes (such as 10 and 30) were connected to the positive AC line and the other cell and electrode were connected to the negative side. When the switch was closed to supply the current to the charge, explosion occurred virtually instantaneously.

It will be evident from the above description that a device such as illustrated in FIGS. 1 and 2, can be securely fastened to its cable and lowered down a bore hole to explode at any desired depth. The thickness of the walls of the housing 2 may be varied in accordance with the effect desired and the direction in which the force of the explosion is needed. Since the contents of the chamber are normally at a pressure of less than three (generally between 1 and 3) atmospheres, a thick and heavy wall is not required during shipment and placement. Devices of the character described hereinabove may also be used in artillery, cannon and naval guns to propel missiles. By making the housing strong and providing the end away from the base with a suitably shaped nozzle, the charge may be caused to generate a tremendous, directed thrust.

FIG. 3 illustrates one adaptation of the method and means of the present invention to use in artillery. As there diagrammatically shown, the two cells 10' and 20' are shown formed within and adjacent the front face of a breach block 3' at the rear end of a gun barrel

4. The two electrodes 30' and 40' with their capacitor plate and coil assembly, are shown removably attached to the inner face of the breach block 3' and the conductors leading to the rearwardly positioned contact terminals. The gun barrel is provided with an injection port 15 and a suitable fitting 16 which may include one or more check valves, said fitting being connected to a high pressure injection line 17 and a proportioning pump which may rapidly feed a predetermined volume of premixed charging gases into the chamber 1 formed within the rear of the gun barrel between the breach block 3' and a shell or projectile generally indicated at 44. An arrangement as diagrammatically illustrated here permits replacement of the electrodes, capacitor and coil, the activating cells 10' and 20' having a long life. It may be noted that the radiations and emanations from the elements contained in the cells 10' and 20' will readily penetrate 1 inch of armor plate when suitably excited by the current supplied when detonation is desired.

The primary function of coil 33 is to heat the gases; in the event this coil fails for any reason, coil 25 can be relied upon to cause detonation by supplying such coil with a current of higher voltage and amperage.

Rays and electrons from the cells, under the stimulated and accelerating effect of the electric current and heat, impinge upon the electrons and nuclei of the gaseous components and their velocity is greatly increased thereby and by the heat generated by coil 33. Collisions, structural changes and alterations apparently take place causing changes in the gas atoms which culminate upon the discharge of the capacitor in a combination of nuclei and the liberation of an enormous amount of energy. Although all of the theoretical aspects of the mechanism which takes place in the chamber is not completely understood at the present time, the fact remains that by the use of the elements, proportions, arrangements and conditions here disclosed, explosive forces of great value and utility may be generated. By changing the form of the chamber, as by elongating it and initiating the wave at one end of the chamber, low brisance effects can be obtained. Those skilled in the manipulation of detonating charges will have no difficulty in adapting the mode of operation of the present invention to many uses and adaptations. All modifications coming within the scope of the appended claims are embraced thereby.

I claim:

1. A method of generating explosive forces which comprises:

positioning at least one pair of spaced capacitor plates in a virtually gas tight chamber, each of said capacitor plates being provided with a conductor communicating with the exterior of said chamber; providing a coil of heat resistant material between said conductors within the chamber, said coil being adapted to become incandescent when said conductors are supplied with electrical current insufficient to discharge the capacitor plates; positioning a pair of activating cells, each containing an element having the ability to emit radiations from the group including alpha, beta, gamma, ultraviolet and X-rays within effective range of the capacitor plates;

injecting a mixture of gases into said chamber, the major proportion of said gases being composed of noble gases and elements whose atoms do not have their outer quantum levels completely satisfied with orbital electrons;

and supplying said cells and conductors with electrical current to accelerate the radiations from said cells, heat the entrapped gases and load the capacitor to discharge the same and generate an explosive atomic reaction in said chamber.

2. A method as stated in claim 1 wherein the capacitor plates are spaced from each other to permit said gases to circulate therebetween.

3. A method as stated in claim 1 wherein the mixture of gases contains xenon, argon and neon.

4. A method as stated in claim 1 wherein the mixture of gases contains from about 40 percent to about 60 percent of argon, from about 30 percent to about 40 percent xenon, and from about 6 percent to about 8 percent of neon.

5. A method as stated in claim 1 wherein the elements contained in said cells are from the group of phosphorous, rubidium, mesothorium, radium and their isotopes.

6. A method as stated in claim 1 wherein said coil is made of wolfram and is adapted to become luminous before the capacitor discharges through said gases under the influence of the current supplied.

7. A method of generating explosive forces which comprises:

injecting and trapping a mixture of gases at a pressure not above about 4 atmospheres in a substantially gas tight chamber, the major proportion of said gases being composed of noble gases and elements whose atoms do not have their outer quantum levels completely satisfied with orbital electrons, and their isotopes;

bombarding said gases with radiations from cells containing elements having the ability to emit radiations from the group including alpha, beta, gamma, ultraviolet and X-rays by stimulating radiation from said cells by supplying the cells with electric current from an external source;

permitting said gases to circulate between spaced capacitor plates positioned in said chamber; and supplying electric current to said capacitor plates to detonate said mixture of gases.

8. A method as stated in claim 7 wherein the mixture of gases contains from about 40 percent to about 60 percent argon, from about 30 percent to about 40 percent xenon, from about 6 percent to about 8 percent neon, and small quantities of chlorine and water.

9. A method as stated in claim 1 wherein one of said cells contains an element of larger atomic mass than

the other.

10. A detonating device comprising a gas tight housing enclosing a chamber containing a pair of capacitor plates in parallel planes spaced to permit movement of gases therebetween, each of said plates being provided with a positioning conductor terminating exteriorly of said housing;

a pair of activating cells in spaced relation with respect to each other and to said capacitor plates, each cell containing an element having the ability to emit radiations from the group including alpha, beta, gamma, ultraviolet and X-rays; each of said cells being provided with a conductor terminating exteriorly of said housing;

sealable means for injecting a mixture of gases into said chamber the major proportion of said gases being composed of noble gases and elements whose atoms do not have their outer quantum levels completely satisfied with orbital electrons, and means for stimulating radiation from said cells including means for supplying alternating current thereto.

11. A detonating device as stated in claim 10 wherein the ends of the positioning conductors, removed from the cells, are connected by a coil adapted to become luminous under the influence of an electric current supplied to said positioning conductors.

12. A method as stated in claim 1 wherein the mixture of gases contains from about 40 percent to about 60 percent argon, from about 30 percent to about 40 percent xenon, from about 6 percent to about 8 percent neon and small quantities of chlorine and deoxygenated water, and the elements contained in the cells are in an atmosphere of argon.

13. In a detonating device, the combination of: a gas tight housing enclosing a chamber containing a pair of capacitor plates in parallel planes spaced to permit movement of gases therebetween, each of said plates being provided with a positioning conductor terminating exteriorly of said housing;

an atmosphere, in said chamber, composed of a mixture of noble gases and elements whose atoms do not have their outer quantum levels completely satisfied with orbital electrons,

a pair of activating cells in spaced relation with respect to each other and to said capacitor plates, each cell containing an element having the ability to emit radiations from the group including alpha, beta, gamma, ultraviolet and X-rays;

each of said cells being provided with a conductor terminating exteriorly of the housing; and means for supplying electric current to said cells and positioning conductors.

* * * * *

55

60

65