

EDWIN V. GRAY

PATENT APPLICATION

- (21) Application No
- (22) Date of filing
21 Aug 1978
- (23) Claims filed
18 Jul 1979
- (43) Application published
10 Apr 1980
- (51) INT CL³ H02M 3/02
H02J 7/00
- (52) Domestic classification
H2J 2JX QSP
H2H BCH
- (56) Documents cited
GB 1358942
GB 1358941
GB 1309661
GB 1302102
GB 1228410
GB 999978
- (58) Field of search
H2F
H2J
- (71) Applicant
Zetex Limited
Box 61
Grand Cayman

Cayman Islands
BWI
(72) Inventor
Edwin Vincent Gray
(74) Agents
Haseltine Lake & Co

may be of particular value in elec-
tromagnetic propulsion systems.

(54) Regenerative energy recovery system e.g. for electromagnetic propulsion

(57) Back e.m.f. can result in energy loss, or inefficient use of energy, in inductive circuits. A regenerative energy recovery system embodying the present invention employs switching 6 to discharge a capacitor 3, through an inductive load 5, e.g. a motor. When capacitor 3 is discharged, a diode 4 creates an alternative circuit path through which inductively maintained current may then continue to flow, for example to charge a battery 7. The invention

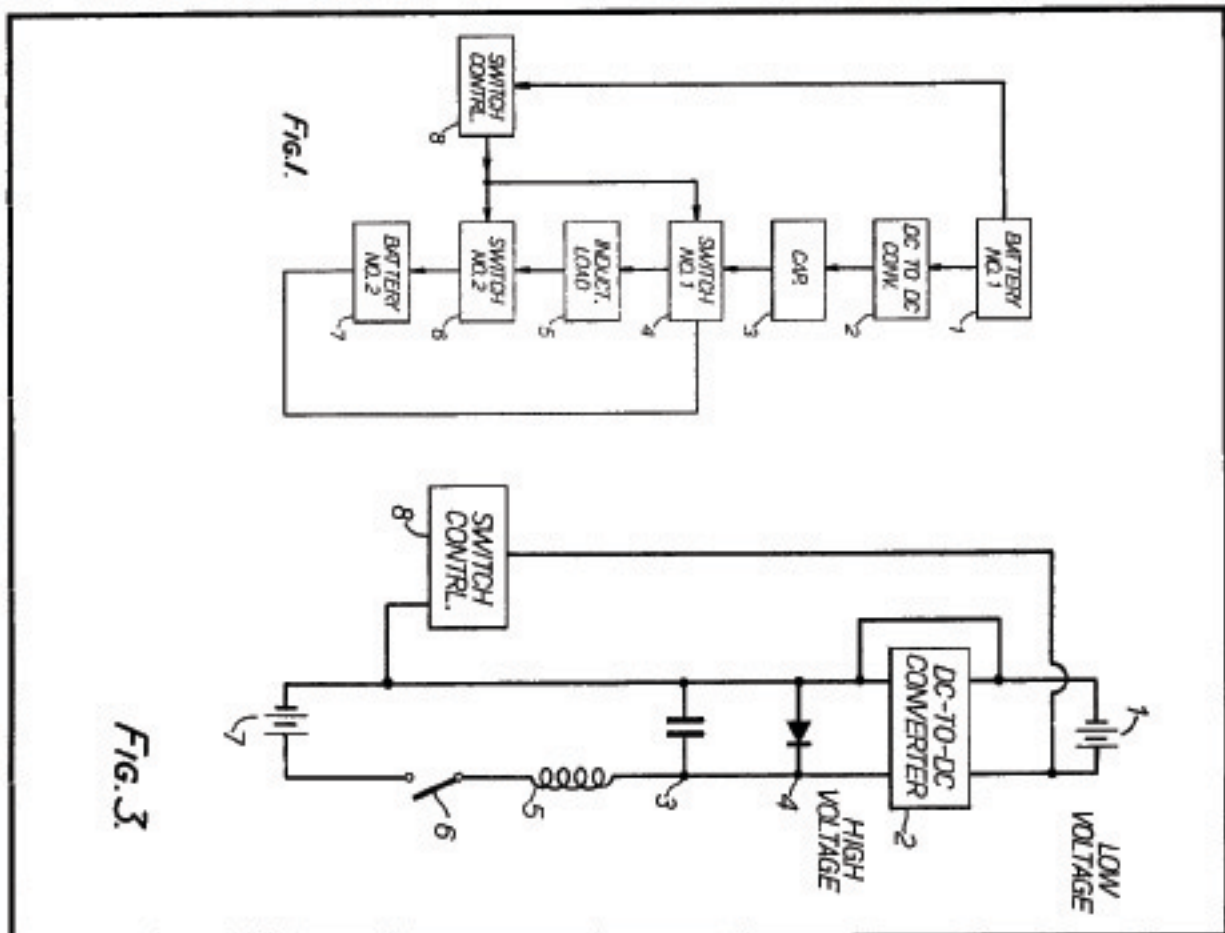

The drawing(s) originally filed was/were informal and the print here reproduced is taken from a later filed formal copy.

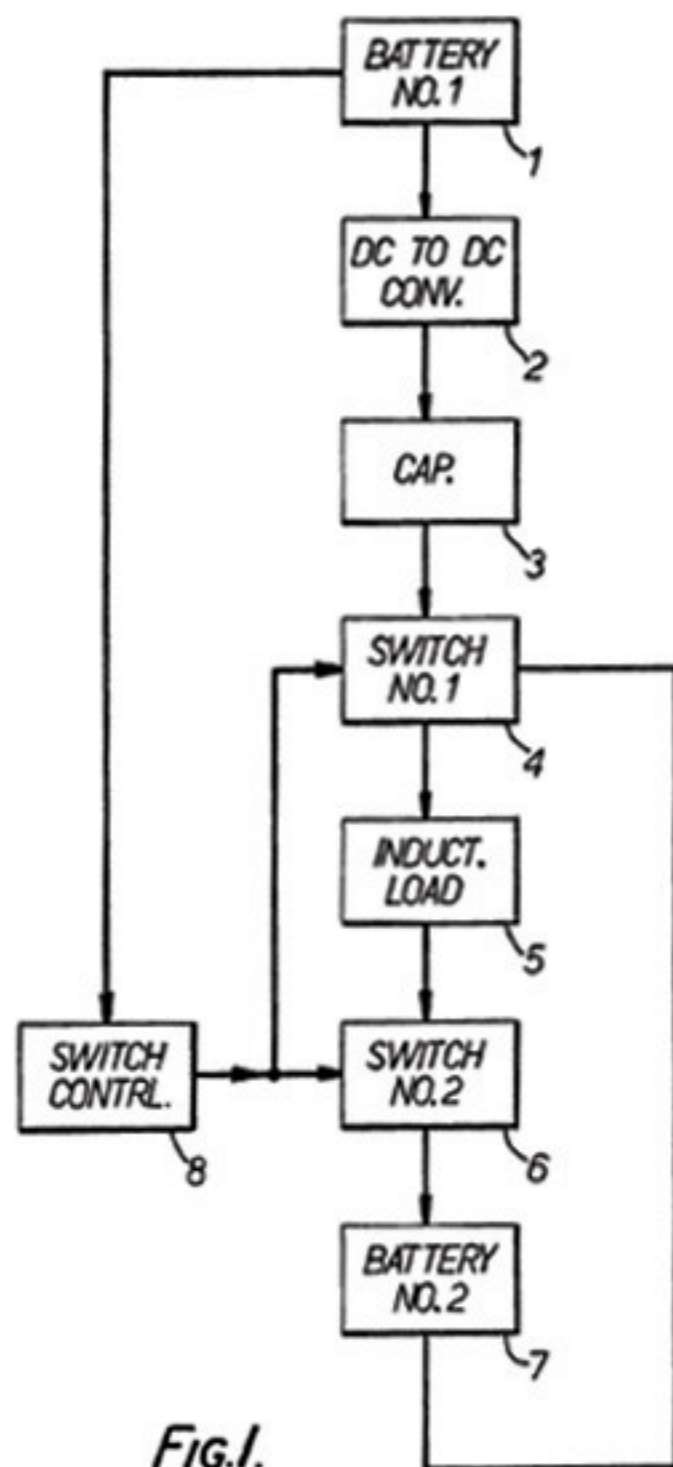

FIG. 1.

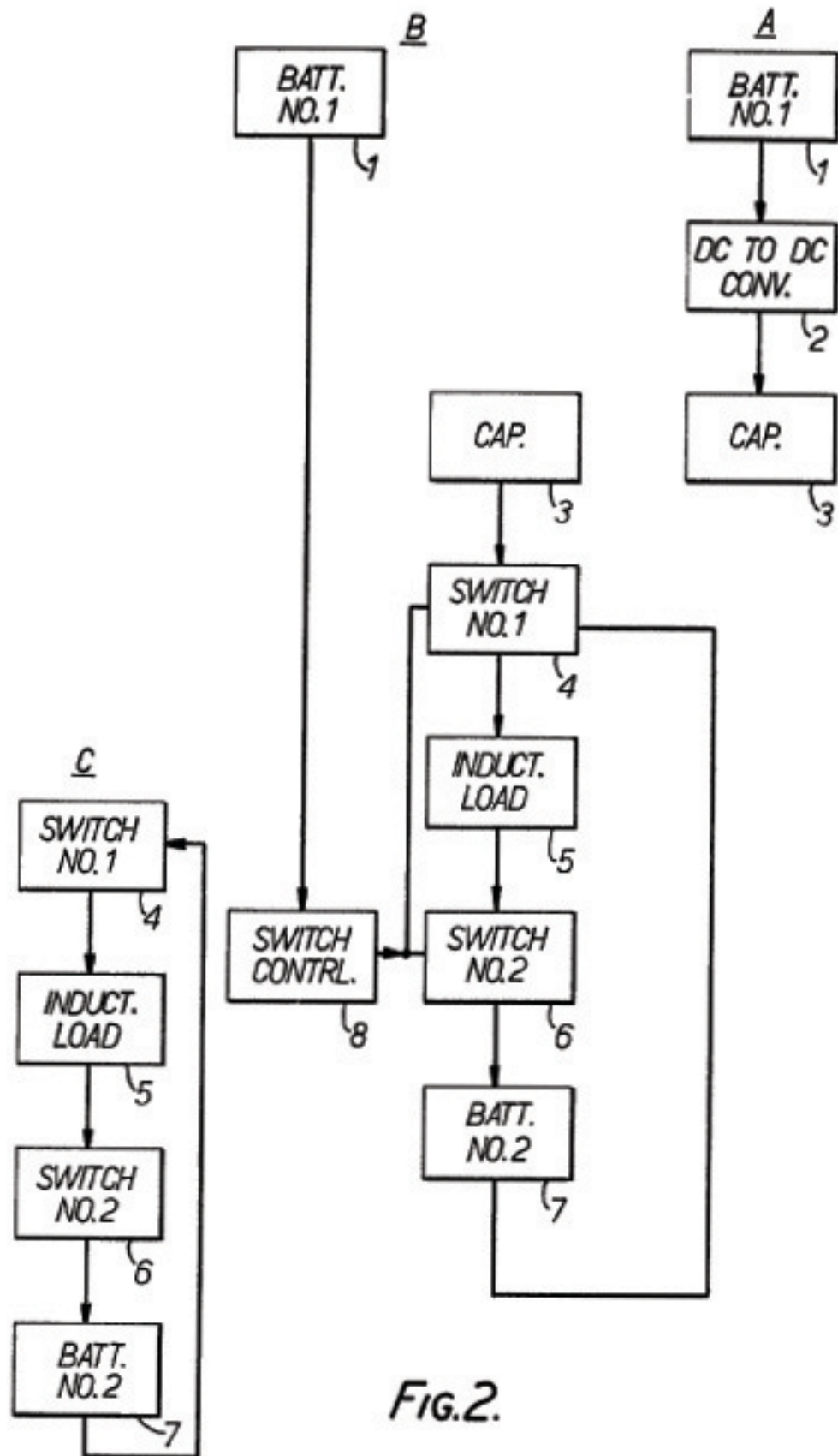

FIG. 2.

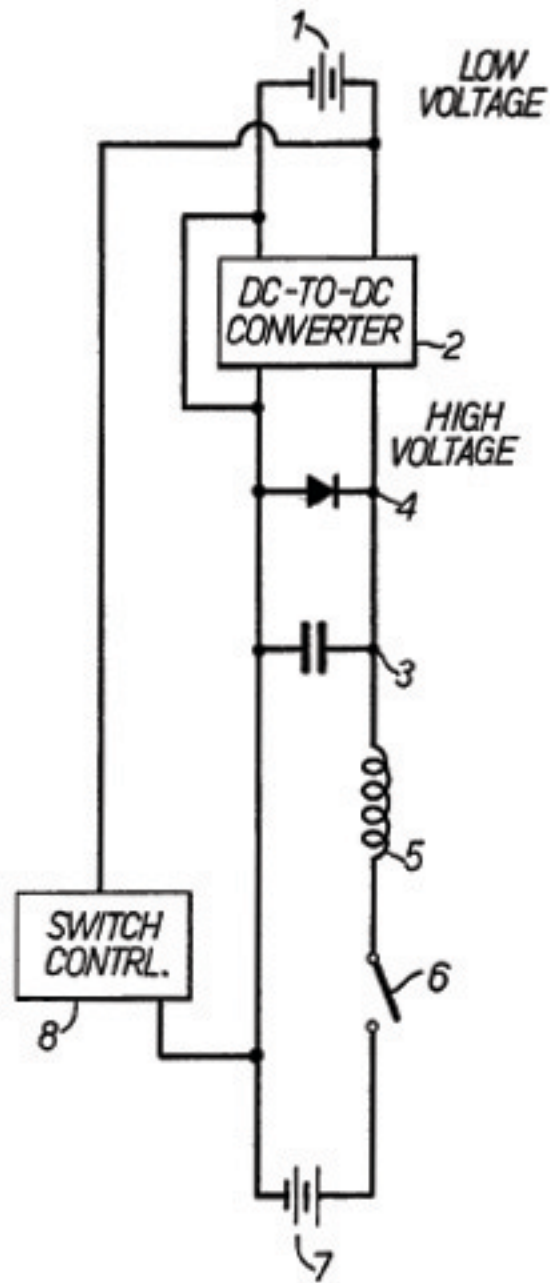

FIG. 3.

SPECIFICATION

Regenerative energy recovery system

5 BACKGROUND OF THE INVENTION

The inventor believes this to be a unique and novel approach to the control of electrical energy for possible future application for the propulsion of inductive devices.

- 10 Through the use of certain inductive devices which enables the device to hold for a short period of time discharges of the capacitors to an external inductive load. The back EMF produced is captured and stored for future use. The result, then being, that the inventor believes this to be a more efficient use of energy.

SUMMARY OF THE INVENTION

- 20 The invention relates to "The Regenerative Energy Recovery System" designed into a configuration wherein energy is momentarily stored for subsequent release for use in propelling electromagnetic devices.

- 25 The "Regenerative Energy Recovery System" is designed to accept a high potential charge from a capacitor which has been charged from a high voltage power source. When the magnitude has been attained at a high level, this will cause a high current spike which can then be utilized into the inductive load. A part of the EMF, that is lost normally, is re-captured and re-routed and stored for future use.

- 35 According to the preferred embodiment of this invention is an energy conserving system. Exemplary embodiments of the invention are herein illustrated. These exemplary illustrations and descriptions should not be construed as limiting the invention to the embodiments shown, because those skilled in the arts appertaining to the invention may conceive of other embodiments in the light of the description.

- 45 **DESCRIPTION OF THE PREFERRED EMBODIMENT**

As herein mentioned, the basic principle of the regenerative energy recovery system, will be explained using the simplified block diagrams of Fig. 1 and Fig. 2.

Figure 1 shows all the major and necessary components in simplified block form.

- 55 Figure 2 duplicates Fig. 1 but is broken into the three (3) sections A, B, and C, corresponding to the three phases of operation of the process which takes place sequentially. The explanation will use Fig. 2, but also applies to Fig. 1.

- 60 Figure 3 shows an electrical schematic view of the system of Figs. 1 and 2.

BRIEF DESCRIPTION OF DRAWINGS

- 65 During phase A a capacitor (item 3) is charged to a high voltage of about 2,000

volts. Battery No. 1 shown as 24V (item 1) has its voltage charged to 2,000 volts by the use of DC to DC converter (item 2). Item 1 is shown as a battery because that is usually a portable electrical energy source. Item 2 is any means suitable to change a low voltage to a high voltage. The phase A purpose is to obtain a high voltage charge in a suitable capacitor.

- 70 During phase B the capacitor (item 3) charged to a high voltage is discharged by closing the normally open (N.O.) switch (item 6). The switch control (item 8) programs when the switches (items 4 and 6) are operated. The discharge current is rapidly passed through switch number 1 (item 4), through the inductive load (item 5) and through the now closed switch number 2 (item 6), and through the energy recovery battery number 2 (item 7). Phase B continues until the capacitor approaches zero voltage whereupon the inertia of the current in the inductance of the inductive load would normally start an overshoot on reversed charge into the capacitor.

- 90 During phase C, the switch number 1 (item 4) disconnects capacitor (item 3) without interrupting the current flowing in the path described in phase B. That is, the current path is through items 5, 6, 7 and back through item 4 into the inductive load (item 5) in a closed loop.

Switches, items 4 and 6 are any devices which will perform the desired switching function in the corresponding parts of the circuit.

- 100 Inductive loads (item 5) may be a single load, or multiple loads. If a single load, the circuit may be duplicated so two inductive loads can interact in an inductive configuration.

- 105 If a single load, a permanent magnetic field may also be used so two interacting magnetic fields can cause force and motion. If multiple loads, one may be designated a rotor load. Suitable polarities will determine whether attractive or repulsive interaction will occur. The timing of the discharge will occur at the instant the loads are properly positioned. The timing of discharge will be determined by the switch control.

- 115 **CLAIMS**

1. A regenerative energy recovery system substantially as hereinbefore described with reference to Figs. 1 and 2 of the accompanying drawings.

- 120 2. A regenerative energy recovery system substantially as hereinbefore described and as illustrated in Fig. 3 of the accompanying drawings.